



UET Mixers
 26 Maple St.
 Mechanic Falls, ME 04256
 Tel: (207)-345-3330
 Toll Free: (888)-838-9131
 Fax: (603)-627-9328

XCEL-2

**TABLE OF
 CONTENTS**

-

TABLE OF CONTENTS

Bulletin 01-050 (Recommended bolting torques).....Pg.1

Bulletin 02-125 (Installation of Mixer Drive Size 2).....Pg. 2

Bulletin 02-126 (Installation of Mixer Drive Size 2 Grease Lube Only).....Pg. 3

Bulletin 04-125 (Maintenance of Mixer Drive Size 2).....Pg. 4

Bulletin 04-126 (Maintenance of Mixer Drive Size 2 Grease Lube Only).....Pg. 5

Bulletin 05-125 (Lubrication of Mixer Drive Size 2).....Pg. 6

Bulletin 05-126 (Lubrication of Mixer Drive Size 2 Grease Lube Only).....Pg. 8

Bulletin 07-125 (Mixer Drive Parts Guide for Size 2).....Pg. 9



Recommended Bolting Torques

1. Tightening Torques

Use the values specified in the following table for fastening motors, units, and accessories to their mounting surfaces with SAE Grade 5 non-lubricated fasteners. If the tightening torque exceeds the capacity of the torque wrench, use a torque multiplier.

Thread Dia-UNC (in)	Painted Metal to Painted Metal (lb-in)	Painted Metal to Concrete (lb-in)
.250-20	90	70
.314-18	185	145
.375-16	330	255
.500-13	825	640
.625-11	1,640	1,280
.750-10	2,940	2,290
.875-9	4,560	3,750
1.000-8	6,800	5,600
1.125-7	8,900	7,000
1.250-7	12,600	10,000
1.375-6	16,500	13,000
1.500-6	22,100	17,500



Installation of Mixer Drive Size 2

1. General

These operating instructions are intended to help you install and operate the drive. For trouble free service, proper installation and operation are essential.

2. Instructions

A. The drive unit should be mounted on a flat, vibration damping, and torsionally rigid structure. Careful alignment is critical. Mounting to an uneven surface will cause housing distortion. The flatness tolerance of the supporting surface should not exceed 0.004 inch.

B. If your unit is direct drive (ie. no gearbox) proceed to Step C. For transportation the units are supplied as sealed gearboxes, i.e., in place of the breather plug, a pipe plug has been installed. The breather plug accompanies the unit in a poly bag. After installation, install the breather in place of the plug. In addition, the oil level should be checked. Remove the oil level plug (See figure 1). The oil level is correct when the surface of the oil is even with the lowest point of the tapped hole. If low use an oil as recommended in bulletin 05-125.

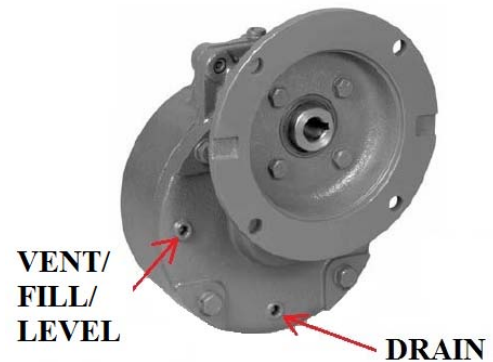

Figure 1

C. View the pedestal and locate access holes to the low speed coupling. Loosen, but take care not to remove the bottom three set screws on the coupling inside the mixer housing. This will allow insertion of the mixer shaft as described in Step D.

D. Insert the end of the mixer shaft that has the flat on it, through the opening in the bottom of the mixer housing and into the coupling. Make sure shaft is aligned so set screws will bear down on the flat when tightened. The shaft should slide into the coupling about 4.5" and then stop.

E. Tighten the set screws on the coupling to bear down on the flat portion of the mixer shaft with an Allen wrench.

F. Position the propeller on the lowest point of the mixer shaft. If two propellers are supplied, locate the bottom propeller as previously instructed and the top propeller 1 to 2 propeller diameters above the lower one. Note that if one of the propellers is supplied with a stabilizing ring, it is always located in the bottom position.

G. Proceed to Bulletin 03-100, Mixer Operation.



Installation of Mixer Drive Size 2 (Grease Lube Only)

1. General

These operating instructions are intended to help you install and operate the drive. For trouble free service, proper installation and operation are essential.

2. Instructions

- A. The drive unit should be mounted on a flat, vibration damping, and torsionally rigid structure. Careful alignment is critical. Mounting to an uneven surface will cause housing distortion. The flatness tolerance of the supporting surface should not exceed 0.004 inch.
- B. These units are finished completely sealed as standard. The grease level should be checked by removing the full and drain plugs. The level is correct when grease exits the drain hole while pumping in the fill port (see Figure 1). Use a Grease as recommended in bulletin 05-126.

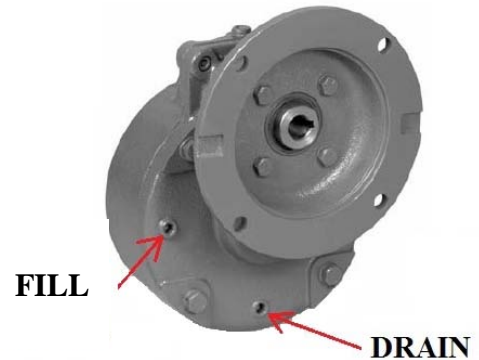

Figure 1

- C. View the pedestal and locate access holes to the low speed coupling. Loosen, but take care not to remove the bottom three set screws on the coupling inside the mixer housing. This will allow insertion of the mixer shaft as described in Step D.
- D. Insert the end of the mixer shaft that has the flat on it, through the opening in the bottom of the mixer housing and into the coupling. Make sure shaft is aligned so set screws will bear down on the flat when tightened. The shaft should slide into the coupling about 4.5" and then stop.
- E. Tighten the set screws on the coupling to bear down on the flat portion of the mixer shaft with an Allen wrench.
- F. Position the propeller on the lowest point of the mixer shaft. If two propellers are supplied, locate the bottom propeller as previously instructed and the top propeller 1 to 2 propeller diameters above the lower one. Note that if one of the propellers is supplied with a stabilizing ring, it is always located in the bottom position.
- G. Proceed to Bulletin 03-100, Mixer Operation.



Maintenance of Mixer Drive Size 2

1. Preventive maintenance for gear driven units only--Always fill the unit with oil to the level plug indicated in Bulletin 05-125, Fig. 1. Also, make sure that the breather is fully functional. Use an oil as recommended in bulletin 05-125.
 - A. **After First Week**--Check alignment of the total system and realign where necessary. Also, tighten all external bolts and plugs where necessary. DO NOT readjust the internal gear or bearing settings in the reducer; these were permanently set at the factory.
 - B. **After First Month's Service**--Proceed as follows:
 1. Operate unit until sump oil reaches normal operating temperature. Shut the unit down and drain immediately.
 2. Immediately flush unit with an oil of the same type and viscosity grade as the original charge (warmed approximately 100° F in cold weather). Rapidly pour or pump a charge equal to 25-100% of the initial fill thru the unit or until clean oil flows through the drain.
 3. Close the drain and refill the unit to the correct level with new or reclaimed oil of the correct type and viscosity. If determined to be in good condition by supplier, reclaimed oil may be reused if it is filtered through a 40 micron or finer filter.
 - C. **Periodically**--Carefully check the oil level of the unit when it is stopped and at ambient temperature, add oil if needed. If the oil level is ABOVE the level mark, have the oil analyzed for water content. Moisture in the oil may indicate that a seal is leaking. If so, replace the defective part immediately and change the oil. DO NOT fill above level plug (if applicable) as leakage or undue heating may result. Also check coupling alignment to make certain that foundation settling has not caused excessive misalignment.
2. EVERY 2500 OPERATING HOURS OR NOT LESS THAN ONCE EVERY SIX MONTHS --
 - A. **Oil Changes**--For normal operating conditions, change gear R&O lubricants every six months or 2500 hours of operation, whichever occurs first. In dusty areas or where temperatures are high, more frequent changes may be required. Lubricant suppliers can test oil samples from the drive periodically and recommend economical change periods based on the rate of lubricant contamination and degradation.

If the drive is operated in an area where temperatures vary with the seasons, change the oil viscosity grade to suit the temperature.



Maintenance of Mixer Drive Size 2 (Grease Lube Only)

1. Preventive maintenance for gear driven units only--Always fill the unit with grease as indicated in Bulletin 05-126, Fig. 1. Use grease as recommended in bulletin 05-126.
 - A. **After First Week**--Check alignment of the total system and realign where necessary. Also, tighten all external bolts and plugs where necessary. DO NOT readjust the internal gear or bearing settings in the reducer; these were permanently set at the factory.
 - B. **After First Month's Service**--Proceed as follows:
 1. Operate unit until sump grease reaches normal operating temperature. Shut the unit down and drain immediately.
 2. Close the drain and refill the unit to correct level with new grease of the correct type and viscosity.
 - C. **Periodically**--Carefully check the grease level of the unit when it is stopped and at ambient temperature, add grease if needed.
2. EVERY 5,000 OPERATING HOURS OR NOT LESS THAN ONCE EVERY TWELVE (12) MONTHS --
 - A. **Grease Changes**--For normal operating conditions, change gear lubricants every twelve (12) months or 5,000 hours of operation, whichever occurs first. In dusty areas or where temperatures are high, more frequent changes may be required.



UET Mixers
 26 Maple St.
 Mechanic Falls, ME 04256
 Tel: (207)-345-3330
 Toll Free: (888)-838-9131
 Fax: (603)-627-9328

XCEL-2

Bulletin 05-125
 11/28/11
 Supersedes 01/24/05

Page
 01 of 02

Lubrication of Mixer Drive Size 2

1. Unit Lubrication for Gear Driven Units Only

Read and carry out all instructions on lubrication plate and heed all warning tags. Determine the output rpm and minimum and maximum temperatures in which the drive will operate. Find the AGMA lubricant number from the following chart.

Output RPM 80 and above	Ambient Temperature	AGMA No.	Viscosity @ 104°F	
			SSU	cSt
	+15° to +60°F	4	626-765	135-165
	+50° to +125°F	5	918-1122	198-242

Select an R&O oil from the table below which corresponds to the AGMA lubricant number previously determined. Lubricants listed in this manual are typical products only and should not be construed as exclusive recommendations. All mineral oil (R&O) lubricants must have a minimum viscosity index of 90.

AGMA Viscosity Grade	4	5	6
ISO viscosity Grade	150	220	320
Viscosity at 104°F	626-765	918-1122	1335-1632
SSU	135-165	198-242	288-352
cSt			
Manufacturer	Lubricant	Lubricant	Lubricant
Amoco Oil Co.	Ind. Oil # 150	Ind. Oil # 220	Ind. Oil # 320
Ashland Oil, Inc.	100H ISO 150	100H ISO 220	100H ISO 320
BP Oil Co.	Turbinol T-150	Energol HL 220	Energol HL 320
Chevron U.S.A., Inc.	AW Machine Oil 150	AW Machine Oil 220	AW Machine Oil 320
Citgo Petroleum Corp.	Citgo Pacemaker 150	Citgo Pacemaker 220	Citgo Pacemaker 320
Conoco Inc.	Dectol R&O Oil 150	Dectol R&O Oil 220	Dectol R&O Oil 320
Exxon Company, U.S.A.	Terresstic 150	Terresstic 220	Terresstic 320
Gulf Oil	Harmony 150 or 150D	Harmony 220	Harmony 320
E.F. Houghton & Co.	Hydro-Drive HP 750	Hydro-Drive HP 1000	...
Imperial Oil Ltd.	Teresso 150	Teresso N 220	Teresso N 320
Kendall Refining Co.	Kenoil R&O 080EP
Keystone Div Pennwalt Corp	KLC-40
Lyondell Petrochemical(ARCO)	Duro 150	Duro 220	Duro 320
Mobil Oil Corp.	DTE Oil Extra Heavy	DTE Oil BB	DTE Oil AA
Petro-Canada Products	Premium Hyd. Oil 150	Premium Hyd. Oil 220	Premium Hyd. Oil 320
Phillips 66 Co.	Magnus Oil 150	Magnus Oil 220	Magnus Oil 320
Shell Oil Co.	Turbo Oil 150	Turbo Oil 220	Turbo Oil 320
Shell Canada Limited	Covil Oil 150	Covil Oil 220	Covil Oil 320
Sun Oil Co.	Sun R&O Oil L150
Texaco Inc.	Regal Oil R&O 150	Regal Oil R&O 220	Regal Oil R&O 320

Note: speed reducer housing temperature will range from 130 to 180 °F during normal operation using the oils listed above. IF your reducer surpasses 180 °F, there may be cause for concern. If the unit is operated in an area where the temperatures vary with the season, change the oil viscosity to suit the season. For cold weather operation, use a light oil that will circulate freely at all times. The pour point of the oil should at least be 9 °F less than the minimum external temperature encountered. During hot weather, use a high viscosity oil that will not thin out and lose its lubricating qualities.



UET Mixers
26 Maple St.
Mechanic Falls, ME 04256
Tel: (207)-345-3330
Toll Free: (888)-838-9131
Fax: (603)-627-9328

XCEL-2

Bulletin 05-125
11/28/11
Supersedes 01/24/05

Page
02 of 02

Lubrication of Mixer Drive Size 2

2. Unit Oil Quantities

Motor Frame Size	Approximate Oil Quantity
56C-145TC	7/8 Pint
182TC-213TC	7/8 Pint

3. Unit Plug Locations

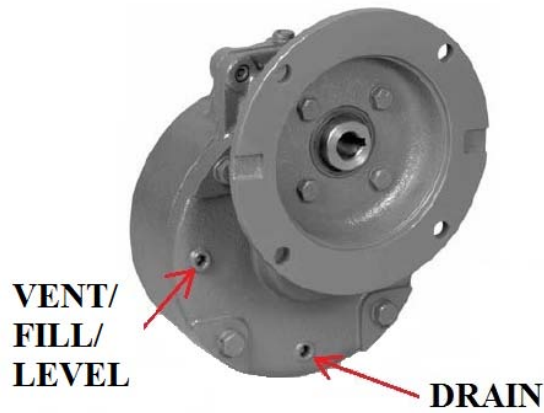

Figure 1



UET Mixers
 26 Maple St.
 Mechanic Falls, ME 04256
 Tel: (207)-345-3330
 Toll Free: (888)-838-9131
 Fax: (603)-627-9328

XCEL-2

Bulletin 05-126
 12/20/11
 Supersedes 10/05/98

Page
 01 of 01

Lubrication of Mixer Drive Size 2 (*Grease Lube Only*)

1. Unit Lubrication for Gear Driven Units Only

Read and carry out all instructions on lubrication plate and heed all warning tags. Find the lubricant number from the following chart.

Grease Properties	
NLGL Number	1 (Min.)
Penetration Unworked	326
Viscosity at 104°F Cst	125
Manufacturer:	Lubricant:
American Lubricants, Inc.	Semi-Synthetic Lithium Complex

Lubricants NOT Recommended – Ordinary grease (regardless of stated viscosity), and EP lubricants that contain sulphur, chlorine or phosphorus compounds (such compounds are extremely corrosive to bronze)

Operational Temperatures- - Although hot to the touch, mixer housings containing grease at temperatures of 130°F to 200°F are not uncommon and are no cause for concern. Operational temperatures above 200°F may signal a problem

2. Unit Grease Quantities

Motor Frame Size	Approximate Oil Quantity
56C-145TC	16 oz.
182TC-213TC	16 oz.

**NOTE: These are approximates. Always fill units to fill line*

3. Unit Plug Locations

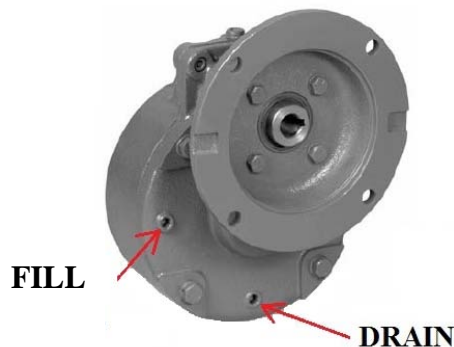

Figure 1



UET Mixers
 26 Maple St.
 Mechanic Falls, ME 04256
 Tel: (207)-345-3330
 Toll Free: (888)-838-9131
 Fax: (603)-627-9328

XCEL-2

Bulletin 07-125
 12/21/11
 Supersedes 10/23/00

Page
 01 of 01

Mixer Drive Parts Guide for Size 2

Ref. Number	Description
1A	Bearing, Low Speed
1B	Bearing, Low Speed
2	Shaft, Low Speed
3	Oil Seal, Low Speed
4B	Bearing, High Speed
5	Shaft, High Speed
6	Oil Seal, High Speed
7	Flange, Motor
8	Screw
9	Key, Gear
10	Gear, Low Speed

Ref. Number	Description
11	Pin, Dowel
12	Spacer, Low Speed
13	Cover, Housing
14	Housing
15	Gasket, High Speed Cover
16	Gasket, Housing
17	Plug, Pipe
18	Plug, Vent
19	Key, Low Speed Shaft
24	Ring, HS Internal Retaining
25	Ring, HS External Retaining

